



GUIDE TO INTEGRATE

LARGE-FORMAT ADDITIVE

Large-format additive manufacturing offers a bigger-picture take on 3D printing. Increasing the build size increases the possibilities for builds: users can create larger parts, removing the constraints of more standard sized build envelopes. 3D printing a large part all at once means less time is spent designing around multiple print jobs, less time assembling multiple parts, and more time getting those parts to work for you.

Getting started with large-format 3D printing can be a big step, but with potentially massive results. It all starts with looking into why you want to 3D print – what your goals are – and what you need to meet your requirements.



I GETTING STARTED

As with any new technology, getting into large-format 3D printing begins with investigation. The first question may be a simple one: what does “large-format” mean?

For 3D printers, “large” is a relative term. Many extrusion-based (FFF) 3D printers are referred to as desktop machines, because they fit on table space. Some of these have very respectable build volumes – but when it comes to “large-format,” the machines will need their own dedicated floor space. Large-format 3D printers have significant build volumes and are most often found in professional settings, like manufacturing facilities and R&D centers.

For BigRep, large-format means a build volume of at least 1000 x 500 x 500 mm – the size of the BigRep STUDIO machine. It only gets larger from there, with the BigRep ONE (1005 x 1005 x 1005 mm), and BigRep PRO (1005 x 1005 x 1005 mm), BigRep EDGE (1500 x 800 x 600 mm).



After finding the right size, more characteristics come into play – materials, speed, and quality chief among them. Will usage mostly be in prototyping or will end-use products requiring engineering-grade materials be created? Is precision the most important element, or are quick mockups key to get to market faster? These and other questions will help narrow the field to find the best-fit solution.

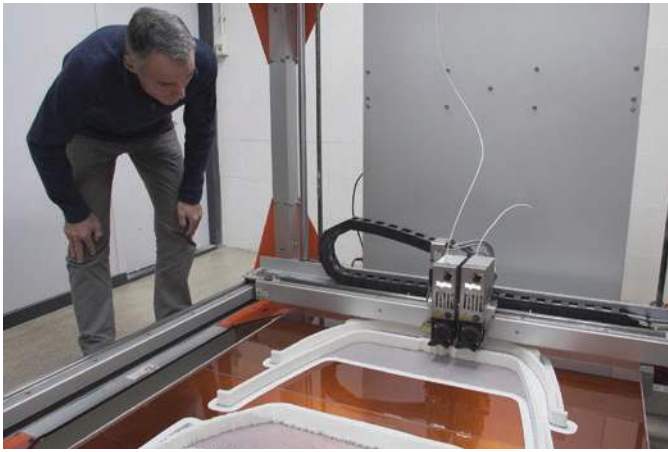

Once a good candidate 3D printer has been found for an equipment investment, there's another all-important step to bringing the technology in-house: management approval. A viable case must be made for any new technology acquisition. Fortunately, 3D printing has been able to showcase strong arguments in its favor. A 3D printer's return on investment can come quickly, with immediate applications that speed up design iteration cycles and bring formerly outsourced steps in-house throughout the workflow. Presenting some initial applications will help management see exactly where large-format 3D printing can make a difference from day one.

With the decision made and the expenditure okayed, the last remaining step is integrating the 3D printer into existing workflows. While some applications have already been laid out, finding new uses for the technology, especially as the team gains experience and builds expertise, can keep the new systems busy and add extra, unforeseen value.

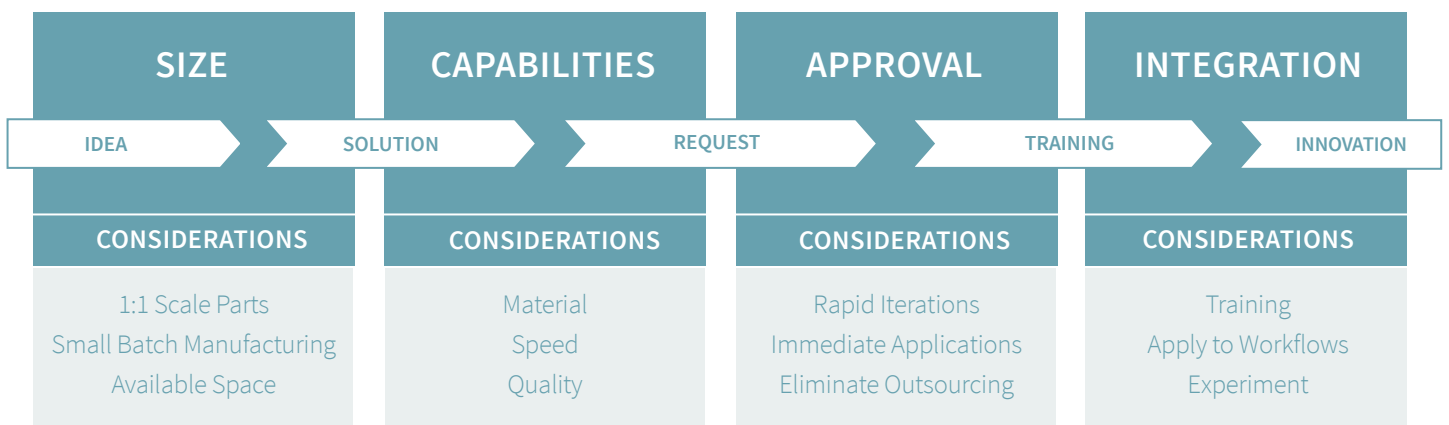

I QUESTIONS TO ASK

Stepping back, it's important to build a realistic picture of what you hope to see happen when investing in new large-format 3D printing capabilities.

SOME HELPFUL EARLY QUESTIONS TO ASK INCLUDE:

How long do you have to produce the prototype, mold, pattern or end-use part?

- Is there time to outsource?
- How long will it take to produce traditionally?
- Will an unusual geometry further increase cost and lead time?

What costs and resources will the traditional method require vs. additive?

- Labor
- Additional equipment
- Post-processing time/processes

When looking into the value of large-format 3D printing, it's important to think about why size matters. What does it enable you to do?

THIS RAISES A FEW MORE IMPORTANT QUESTIONS TO EXPLORE:

If build volume wasn't a limitation could you prototype better with 3D printing?

If you wanted a full-scale replica of your part before going to production how easily could you produce it? What would it cost you? How long would it take?

I SIZE MATTERS

When it comes to the benefits that large-format 3D printing can introduce to your business, several contributing factors come into play. Key considerations include the potential for improvements in speed, costs, and quality.

SPEED	<ul style="list-style-type: none">• Faster iteration cycle• Accelerate time to market
COSTS	<ul style="list-style-type: none">• Eliminate outsourcing• Simplify finishing processes
QUALITY	<ul style="list-style-type: none">• Enable technical staff to develop market leading ideas.• Deliver intricately designed products and components at full specification.

Among the many applications large-format 3D printing sees use in some prominent applications include prototypes made at 1:1 scale, molds, patterns, tooling, and end-use parts. All of which are particularly well-poised for increasing use of 3D printing.

Prototyping was the first, and remains the largest, application area for 3D printing. In industries like automotive and aerospace, where large parts are often needed, parts are prototyped until they are just right and ready for mass production. Being able to do so relatively quickly in-house speeds up the design process and time to market. Ensuring the appropriate fit and function for parts is a critical stage of the design process: getting hands-on with 1:1 scale prototypes allows teams to ensure that all real-world parameters are met, making for accurate final design evaluations.

Molds and patterns are also seeing rising use. While 3D printing is not currently a solution for all end-use part production, the technology is gaining a strong foothold in manufacturing workflows. Creating molds and patterns in-house for use with traditional molding and casting technologies ensures that the specific geometries designed can be captured in the final parts.

Because these prints can be made at full scale, post-processing time is reduced for both prototypes and molds. No gluing or piecing together various parts is necessary as final assemblies can come off a single print bed in one piece.

Large print beds also enable short production runs of many smaller parts. Filling the print bed doesn't necessarily mean one large part; significant build volumes can also mean more parts of varying sizes. Creating tooling and spare parts at the same time can maximize efficiency.

I INTEGRATING ADDITIVE MANUFACTURING

Once the decision has been made to bring in large-format 3D printing, the real work begins.

While additive manufacturing offers new capabilities and a new dimension to production workflow, it is not a replacement technology. While certain processes will move over from traditional technologies to the new 3D printer, the best way to integrate 3D printing is alongside, not instead of, existing workflows. Certain applications are especially well-suited to 3D printing; others do not make financial or feasible sense.

3D printing is another tool in the toolbox.

While applications are broadening and more will come to light through growing expertise with the new system and its design and post-processing workflows, additive manufacturing will not replace every other tool in the toolbox.

Installing a new 3D printer – perhaps even a new large-format machine alongside existing desktop units, or industrial metal 3D printers – adds a new layer of capabilities. The real key to leveraging these new abilities lies in finding best-fit solutions. Sometimes it will still make more sense to hand make or mill a part; other times, a hybrid approach integrating both additive and subtractive manufacturing methods will produce the best results.

The learning curve upon initially bringing 3D printing into operations is relatively steep. Employee training and education is especially critical in early days when design for additive manufacturing (DfAM) courses will ensure that parts are effectively designed to be 3D printed. Using the same designs for a new means of making will not produce the best results, and indeed design files must be optimized for the specific machine they will be made on (e.g., regarding supports, orientation, infill).

Finding the right material for the right job is similarly important. Many familiar polymers are available for large-format 3D printing, but their performance and limitations may be slightly adjusted from legacy production technologies as new geometries and means of making alter their properties. Ensuring that the right printer and material are used together – for example, a high-temperature 3D printer with engineering-grade materials – is critical to ensuring the expected material performance. When a quick mockup is needed, a less expensive commodity material makes more sense than using engineering materials.

FOUR APPLICATIONS THAT BENEFIT FROM LARGE-FORMAT ADDITIVE MANUFACTURING

Large-format 3D printing offers benefits in a number of areas. Many of these will have been explored in initial research phases, others will arise with time and familiarity.

Real-world use cases highlighting four application areas allows for a closer look at some specific ways actual users have been seeing the benefits of large-format 3D printing in their businesses.

PROTOTYPING



TOOLING



PATTERNS, MOLDS & CASTINGS



END-USE PARTS



PROTOTYPING

Steelcase, founded in 1912, is the largest global B2B contract furniture company in the world. The company has had a BigRep ONE 3D printer at its Munich Learning + Innovation Center since November 2016.

The challenge for Steelcase was to produce full-size prototypes of its furniture with a faster turnaround time. Prior to investing in large-format 3D printing, Steelcase's choice was between:

- Well specified full-scale models, costly and requiring several weeks turnaround
- Simpler, usually smaller scale models that lack many specifications

Neither prototyping method was ideal, so Steelcase sought a solution to produce large, accurate prototypes quickly. Enter the BigRep ONE.

The Aluleg for Bfreebeam, for example, is a tall stool designed by Alban Moriniere. Using a 1mm nozzle and a layer height of 0.7mm, a full-sized prototype of the Aluleg was printed in about 34 hours considerably less time than it would have taken with an outsourced or handmade model.

ALULEG FOR BFREEBEAM

Designed by: Alban Moriniere, Sr. Industrial Designer, Steelcase

Dimensions: 160 x 850 x 850 mm

Nozzle: 1 mm

Layer Height: 0.7 mm

Plastic Weight: 6.5 Kg

Filament: Black ProHT

Printing time: 34 hours

Steelcase

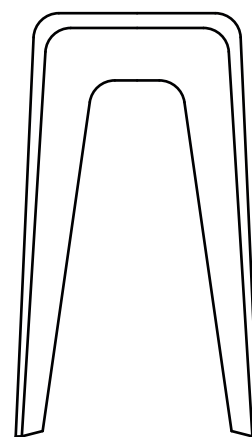

A full-sized tall seat shell was also created much faster and much less expensively than traditional methods. In comparison, the speed of making the prototype was more than 90% faster; the weight-bearing seat shell took only four days to create on the BigRep ONE, while hand production takes two months. Similarly, hand production requires 2-3 weeks of subcontracted labor that was removed from costs by 3D printing the design in-house. Meanwhile designers could be more productive, creating more iterations in less time.



TOOLING

Ford Research & Advanced Engineering Europe is part of a global additive manufacturing team with an additive manufacturing facility located in the Pilot Plant, Cologne. The facility's focus is on functional applications: materials development and evaluation, innovation in printing processes and technologies built on more than 30 years of additive manufacturing experience. The Pilot Plant sees new vehicles designed several years before their mass production.

The Ford team turned to BigRep to create tooling. The challenge ahead of this company was to optimize the time it took to create tools, cost of tooling, and weight of the tools. Examples of success with welding fixtures and hand jigs highlight the applicability of large-format 3D printing for tooling.

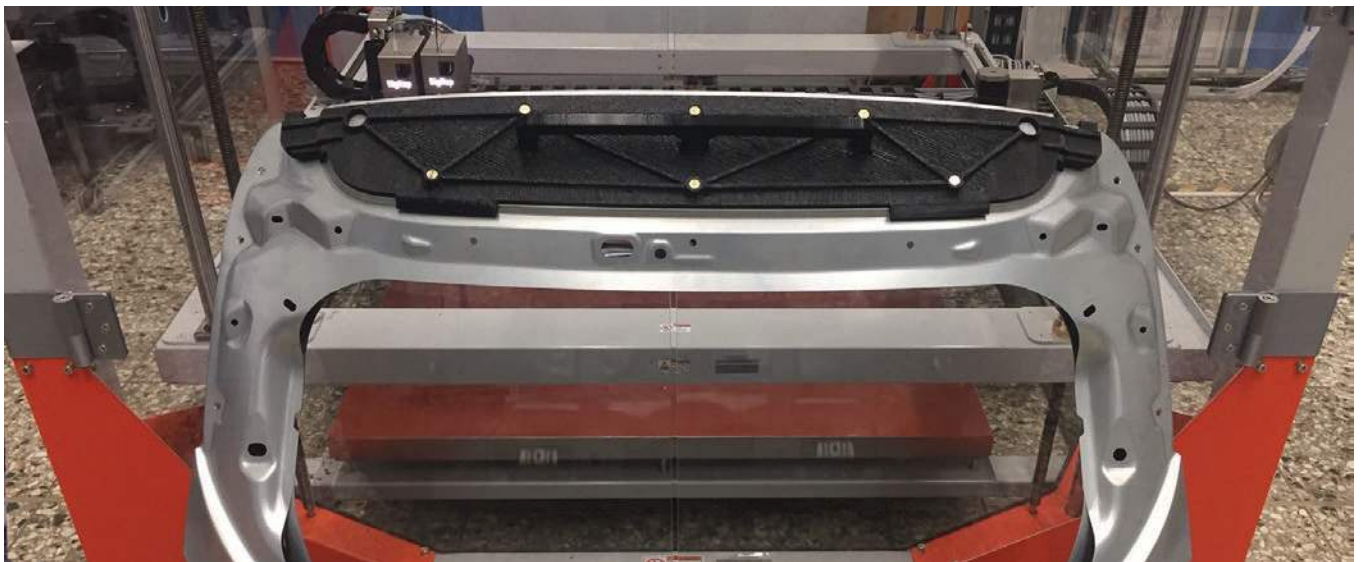

TOOLING WELDING FIXTURES

The welding fixtures used at Ford position sheet metal parts for manual welding operations in the prototyping phase. These are complex assemblies that previously required all their parts to be machined manually. This was less than ideal as they are only needed for one prototype project, and no recycling was possible. Each car requires the use of 190 fixtures and all of these required significant manual work.

Prior to turning to large-format 3D printing for these fixtures, the workflow was complex:

- Design fixture
- Send to third party
- Fixtures machined at third party
- Set up fixture
- Use fixture

Bringing in 3D printing streamlined the workflow:

- Design fixture
- Print fixture in-house
- Use fixture

The time and cost savings efficiencies created provided a fast return on investment (ROI) for this application – the first for Ford’s BigRep 3D printer.

The precision and dimensional stability of the fixtures proved highly functional for their use. This was coupled with BigRep’s materials, which have a high heat deflection, effectively offering the strength of metal



at a fraction of the cost. The fixtures could be printed and then used the next day on the welding table - and with minimized setup time, as each fixture is customized for its specific application. This provided a favorable contrast to using modular welding fixtures, which are imprecise and require additional time for adjustments to fit exact needs.

TOOLING **HAND JIGS**

Ford additionally put its large-format 3D printing capabilities to use in creating hand jigs. These low-volume jigs significantly impact workers' performance.



Traditionally-made hand jigs require many iterations and an 8-10 week lead time. By 3D printing them in-house iterations can be sped up and jigs can be created in just 2-3 days - a 94% time savings when comparing the new 3-day process to the traditional 50-day period.

Hand jigs are used every 60 seconds at the plant - so decreasing the weight of one by just 1kg means that an operator lifts 600kg less per shift, offering a major benefit to working conditions. The ergonomics of these jigs are also important and easily customized to fit the needs of those who will be using them when created with an additive process.

FORD - SENSOR FIXTURE

Designed by: Ford Motor Company

Dimensions: 890 x 1010 x 110 mm

Nozzle: 1 mm

Layer Height: 0.6 mm

Part Weight: 4.1 Kg

Filament: Black ProHT

Printing time: 51 hours

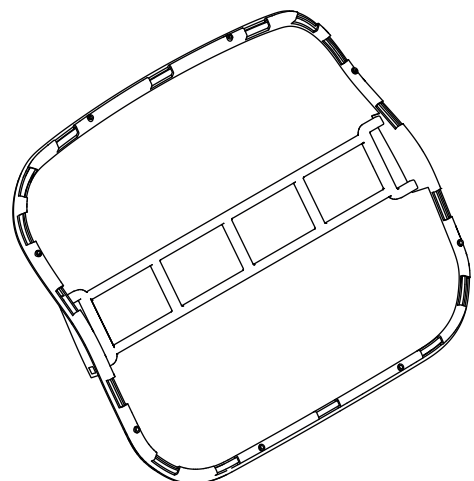

PATTERNS, MOLDS & CASTINGS

Teignbridge Propellers International Limited is a high-performance, marine engineering components company. Over its more than four-decade history, the company has produced its signature custom-designed and -produced propellers for use on tugs, luxury yachts, fishing trawlers, and ferries.

In 2017 Teignbridge invested in a BigRep ONE 3D printer, drawn to the machine for its use in manufacturing sand cast patterns. In those two years the company has significantly cut the time, costs, and labor associated with creating new propeller patterns.



A typical pattern print for a 750mm long design takes just 40 hours to print. Total production time is just 48 hours when including post-processing work. That two days means a 33% faster pattern production time, cut down from three days. A 90% reduction in pattern maker costs further highlights the benefits of bringing large-format 3D printing in-house.

Labor for making propeller patterns is also cut significantly - from 20 hours down to just two hours. Teignbridge explored several options when looking into investing in 3D printing, finding that BigRep has lower associated material costs compared to other systems considered.

By 3D printing in-house, Teignbridge is experiencing less reliance on pattern makers. This reduces the risk of labor shortages or being out-competed by low-wage locations.

TEIGNBRIDGE - PROPELLER

Designed by: Teignbridge Propellers

Dimensions: 515 x 354 x 587 mm

Nozzle: 1 mm

Layer Height: 0.6 mm

Plastic Weight: 3.6 Kg

Filament: Mauer Grau PLA

Printing time: 32 hours

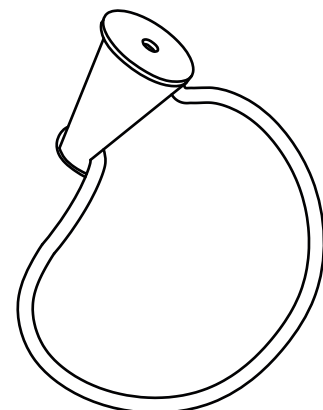

END-USE PARTS

NYC-based Boyce Technologies, Inc. designs and manufactures security and communications equipment for the mass transit market including emergency response systems, intercom systems, security alarm systems, radio and wireless networks, and customer information display systems.

The company operates a variety of manufacturing technologies, including:

- Multi-Axis CNC Subtractive Machining
- Laser Technologies for Cutting and Welding
- Multi-Axis Industrial Robots
- Multi-Axis Waterjet Cutting
- Large-Format 3D printing

In 2017 Boyce Technologies decided to integrate additive manufacturing into its operations. While the company had previously not seen a need for 3D printing in their business, by exploring options and researching viability they changed their position and decided to transform how they produce equipment. The company invested in a BigRep STUDIO system, intending to use it 90% for prototyping and perhaps 10% to create end-use parts.

The reality has turned out to be exactly the opposite.

Boyce put its in-house 3D printing to the challenge of creating parts quickly with high-quality, reliable results. The company is often faced with very short deadlines, in which they either win or lose out on business. Today, uses in prototyping and vacuum forming are helping Boyce move forward – though the majority (90%) of its 3D printing is for end-use parts.

“I didn’t think I needed 3D printing and now I can’t live without it.”

Charles Boyce,
President of Boyce Technologies

In creating end-use parts, Boyce Technologies found several benefits to 3D printing, including:

- Time Savings
- Costs Savings
- Production Capabilities
- Flexibility
- Customization
- Finish Quality

Time to program and prepare jobs has been significantly cut back compared to the traditional subtractive processes Boyce had been using. In one case, they found that 3-6 hours of prep time for CNC aluminum was able to be reduced to 15-30 minutes for 3D printing with plastic. Additionally, subtractive processes can result in 60-80% wasted material which, at \$0.40-.60/pound of aluminum, is not insignificant. Plastic filament on the other hand is \$12/pound without any waste, effectively eliminating extra expenses like waste management and environmental offset costs.

When it comes to post-processing work to finish parts, labor is notably reduced. For metal parts, finishing work required 12 people but now only two people are needed to work on plastic parts, freeing up the team's labor force to work on more projects.



Boyce has been experiencing the benefits of 3D printing in reducing costs and bringing products to market faster. Parts can be made to exacting specifications without outsourcing the work, reducing costs and time to have parts in hand. Furthermore, unlike injection molding, costly tooling is not required when creating end-use parts, so there's no hold-up when a design is ready for production.

BOYCE - COOLING SYSTEM AIR-INTAKE DUCT

Designed by: Boyce Technologies

Dimensions: 127 x 223 x 77 mm

Nozzle: 0.6 mm

Layer Height: 0.3 mm

Plastic Weight: 0.12 Kg

Filament: ProHT

Printing time: 2.5 hours (x1) - 34 hours (x16)

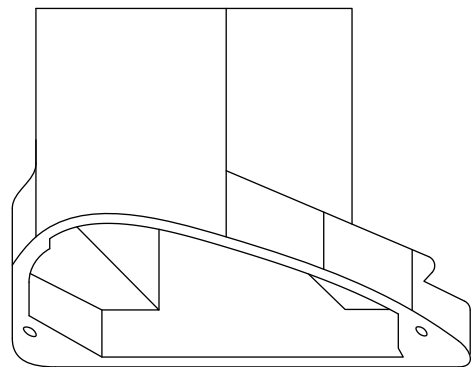

IS LARGE-FORMAT 3D PRINTING FOR YOU?

After asking all the technical and managerial questions, and exploring a few of the many use cases for large-format 3D printing, there's really one lingering question: is it the right fit for your business?



REDEFINING **ADDITIVE**

bigrep.com



EUROPE
Gneisenaustraße 66
10961 Berlin
Germany
Phone +49 30 20848260

NORTH AMERICA
400 West Cummings Park
Suite 1675
Woburn, MA 01801
United States
Phone +1 781 281 0569

APAC
120 Lower Delta Road
#04-04/05 Cendex Centre
Singapore 169208
Phone +65 6909 8191